

Transmitter for kW, 3-phase symmetrical load

Connection to 3-phase net up to 3 x 500 VAC

Monitoring of total power consumption ($\sqrt{3} \times U \times I \times \cos \varphi$)

Built-in current transformer, ranges up to 60 AAC

Analogue output 0-20 mA / 4-20 mA

24 DC supply

Galvanic separation, input - output

Made in accordance with the CE and EMC regulations



FPA38 is monitoring the power consumption on 3-phase symmetrical load, primary motors.

The wanted metering range is selected by means of DIP-switches, from 0-3,46 kW up to 0-41,6 kW at 3x400 VAC supply, proportional to 0-20/4-20 mA on the metering output. 0-10 V is also possible, see below.

The supply voltage, 24 VDC, and the 3 voltage phases are connected to the relevant terminals. The current is monitored by putting the current phase L1 through the built-in current transformer, see connection diagram.

Technical data:

Supply voltage: 24 VDC +/- 5%
Current consumption: max. 60 mA
Operating temp.: -15 to +50°C
Metering rangeV: 3x200 to 3x500 VAC
Metering range I: 5, 10, 20, 25, 40, 60 A
Metering range f: 10-150 Hz
Accuracy: Class 2
Analogue output: selectable 0-20 mA or 4-20 mA
 For 0-10 V output, select 0-20 mA, and then connect pin 7 and 8 (GND og X1)

Note: **The metering output is not galvanic separated from 24 VDC supply.**

Load, outputs: Current: max. 500 Ohm
 Voltage: min. 100 kOhm
Note: Output is short-circuit proof

Reaction time: approx. 200 msec.

Weight: 200 g

Dimensions: 90 x 35 x 57 mm

CE mrk: EN61326A, LVD EN61010

Selection of metering range

The wanted ranges are selected with the DIP-switches on the side of the unit.

Select output signal, 0-20 mA or 4-20 mA with SW1.

SW2, 3 and 4, selection of monitoring current, see table.

SW1	OFF = 4-20 mA			ON = 0-20 mA		
	SW2	SW3	SW4	SW2	SW3	SW4
SW2	OFF	ON	OFF	ON	OFF	ON
SW3	OFF	OFF	ON	ON	OFF	ON
SW4	OFF	OFF	OFF	OFF	ON	ON
Amp	5	10	20	25	40	60
kW	3,46	6,92	13,8	17,3	27,7	41,6

Note: The power ranges in the table are calculated and calibrated with a supply voltage of 400 VAC.

Connection diagram.

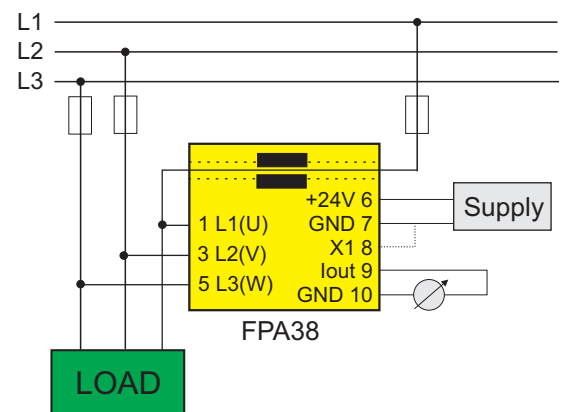

Metering principle.

The FPA 38 is connected to the supply, 3-phase net and load as shown above.

It can also be used together with frequency converters, as it operates in the frequency range 10-150 Hz.

For monitoring of 1-phase loads, connect L2 and L3 to N, and L1 to the phase.

Since the unit is calibrated for 3-phase loads, the output signal must be multiplied with 1.5 in order to get the correct value at 1-phase loads.